



Technical Manual

8.5 x 11 page size version
Updated March 2004



Copyright © 2004 Defy Gravity, all rights reserved.

Parts List

- A** Retention Bolt Screw (18-8 stainless steel, #8/32)
- B** 2 lock washers (18-8 stainless steel, #8)
- C** Tether Lid (7075 aluminum, type II anodizing in green)
- D** Retention Bolt (18-8 stainless steel, .5" x .25", #8/32)
- E** 4 Retention Tabs (304 stainless steel, .060" thick)
- F** Retention Cable (18-8 stainless steel)
- G** Hex Key (3/32)
- H** Tether Cup (7075 aluminum, type II anodizing in green)
- J** 2 Ignitor Seals (neoprene with brass threads, #8/32)
- K** 3 flat washers (18-8 stainless steel, #8)
- L** Cup Mounting Screw (18-8 stainless steel, #8/32)
- M** Cup Screw (18-8 stainless steel, #8/32)

Replacement Parts

Replacement Parts are available from Defy Gravity in case parts become lost or damaged. Tether Lid **C**, Tether Cup **H**, and Tether Accessory Pack is available online at defyg.com. The Tether Accessory Pack contains all parts listed above (except **C** and **H**) in the same quantities, plus two additional parts only available in the Tether Accessory Pack — Cup Eyescrew **N** and Retention Bolt Eyescrew **P** (18-8 stainless steel, #8/32).

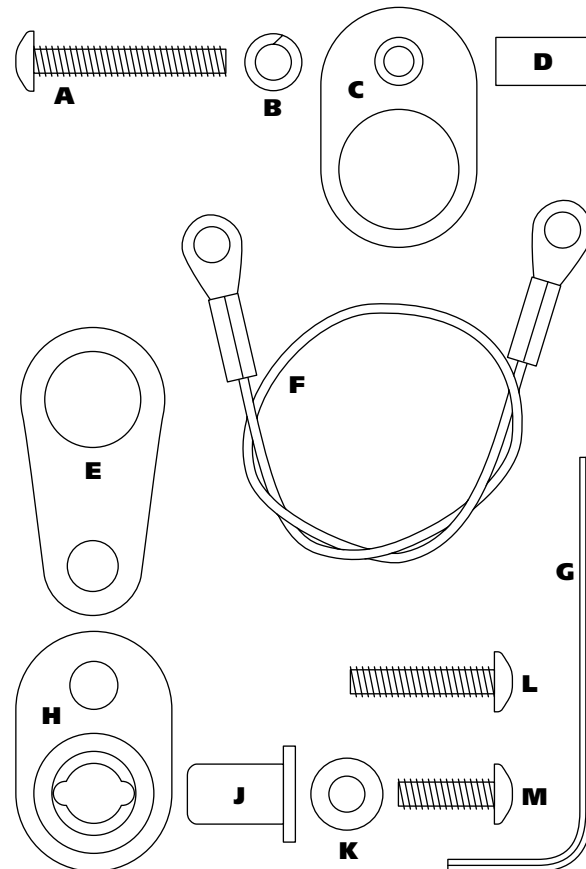
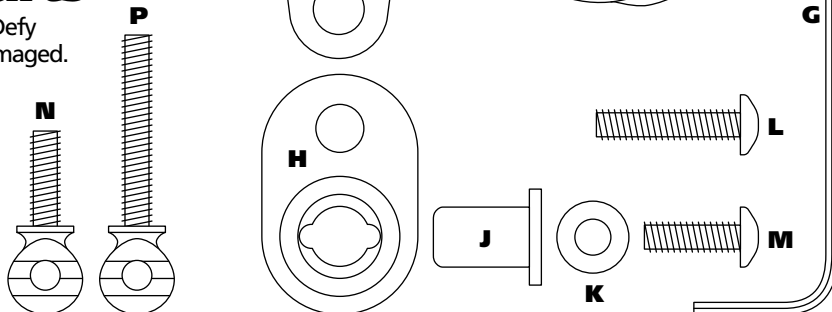

Lid Assembly

Basic Configuration

Pass retention bolt screw **A** through lock washer **B**, one eye of retention cable **F**, into the small side of the bolt hole in Tether lid **C** and thread into retention bolt **D**, then tighten securely.

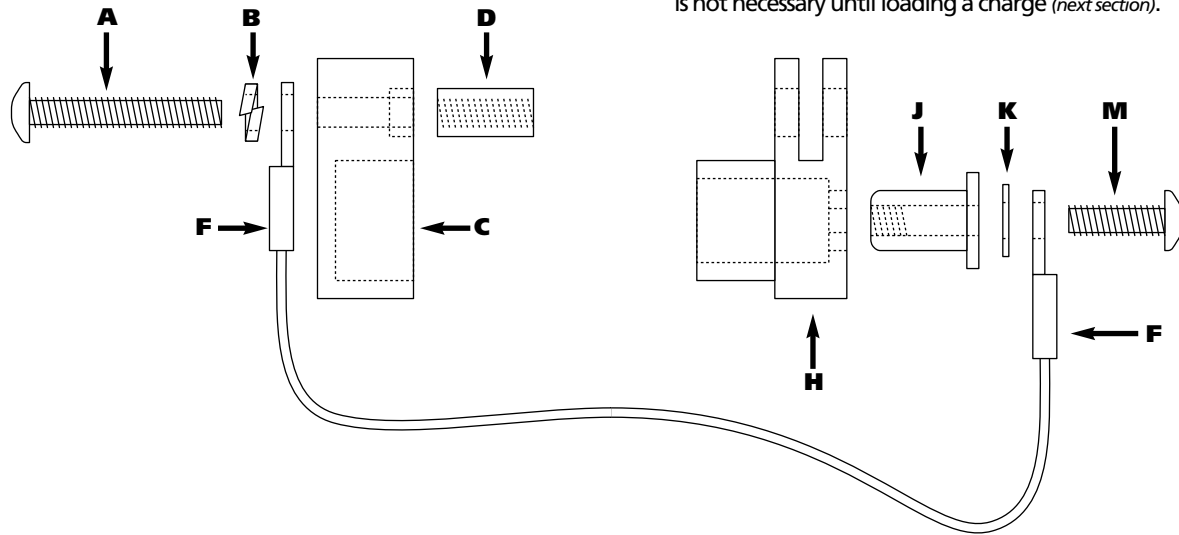

Cup Assembly

Basic Configuration

Pass cup screw **M** through the other eye of retention cable **F**, flat washer **K**, into hole in flanged side of ignitor seal **J** and thread until flange meets flat washer **K** and stop (*do not tighten*). Slide ignitor seal **J** into hole in back of Tether cup **H** until flange meets back surface of Tether cup **H**. Tightening will cause ignitor seal **J** to expand inside the charge cavity, and is not necessary until loading a charge (*next section*).

Lid Assembly

Alternate Configuration

Available only in the Tether Accessory Pack, locate the retention bolt eyescrew **P** and pass it through lock washer **B**, 2 flat washers **K**, into the small side of the bolt hole in Tether lid **C** and thread into retention bolt **F**, then tighten securely.

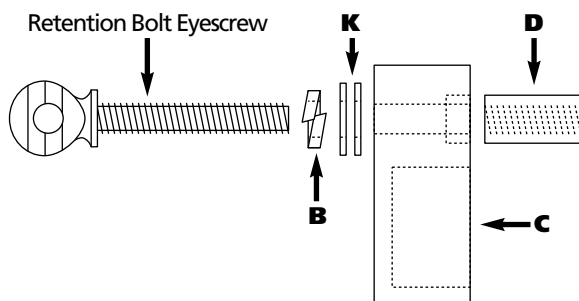

Cup Assembly

Alternate Configuration

Available only in the Tether Accessory Pack, locate the cup eyescrew **N** and pass it through lock washer **B**, flat washer **K**, into hole in flanged side of ignitor seal **J** and thread until flange meets flat washer **K** and stop (*do not tighten*). Slide ignitor seal **J** into hole in back of Tether cup **H** until flange meets back surface of Tether cup **H**. Tightening will cause ignitor seal **J** to expand inside the charge cavity, and is not necessary until loading a charge (*next section*).

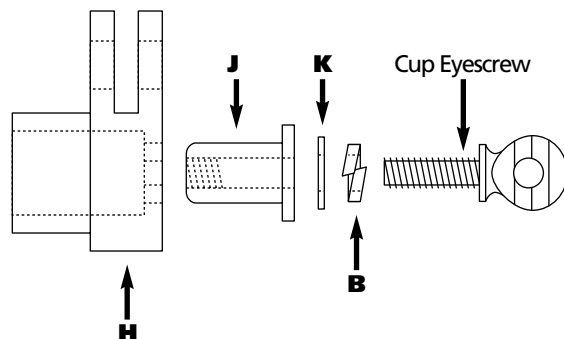

Loading A Charge

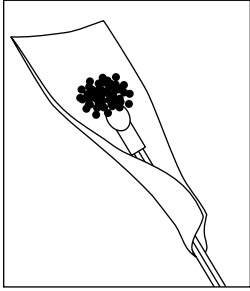

Form a "spoon" of masking tape around the head of an electric match type ignitor. Two ignitors may be used for some redundancy. Place a small amount of ffff black powder or a fine grain black powder substitute, such as Pyrodex, in a pile on the head of the ignitor.

Approximately one-eighth to one-quarter gram, or about two to four times the size of the ignitor head should be used, but you should

perform some ground tests to achieve the appropriate amount for your use. Fold the tape up and over the head to form a small packet of tape to contain the black powder and keep it in good contact with the pyrogen on the head of the ignitor.

You may want to apply a thin coat of grease to the inside of the Tether charge cavity and Tether lid to aid in post firing clean up. Insert the charge, ignitor leads first, into the charge cavity and feed the ignitor leads out the hole in the back of the Tether cup. Pull through until the

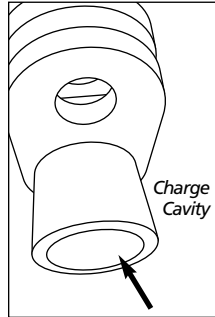

charge is nearly completely in the cavity and position the ignitor leads to seat into the ignitor pathways. Insert the ignitor seal and tighten the cup screw until snug. Do not overtighten. Observe the seal expanding inside the charge cavity as you tighten the cup screw. This will seal the ignitor pathways from any gases escaping once the charge is fired. After tightening the seal, you will have a little more room in the cavity to position the charge below the rim of the cavity, allowing the lid to seat properly. After the lid is put on the cup, place some masking tape on the sides to insure the cup does not loosen or vibrate off. When the charge is fired, the tape will break.

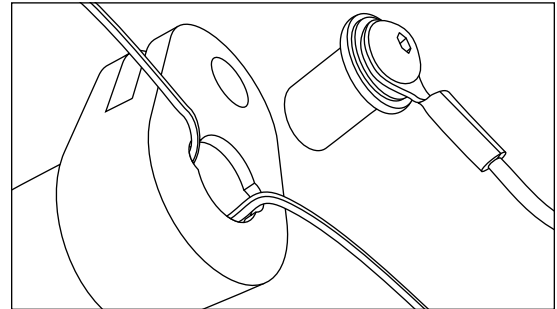
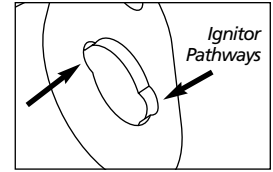

How It Works

Very simply put, when the lid is on, the bolt holds whatever is behind it in place until the charge fires. The gases from the charge need to escape and forces off the lid in the process. The lid pulls the bolt out with it, allowing the tethered item to then be released. Tether can be used to perform a number of tasks.

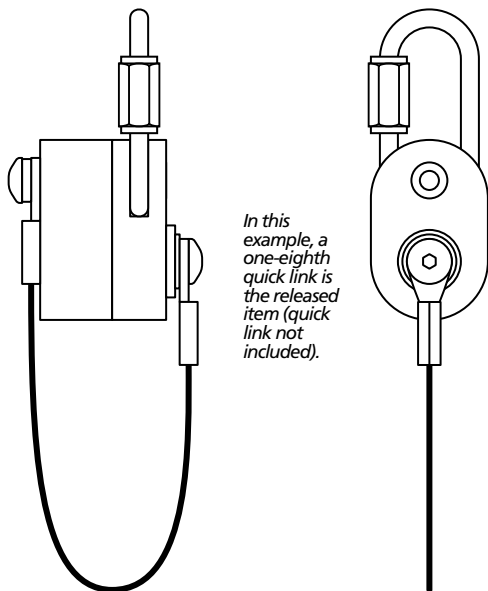

In this example, a one-eighth quick link is the released item (quick link not included).

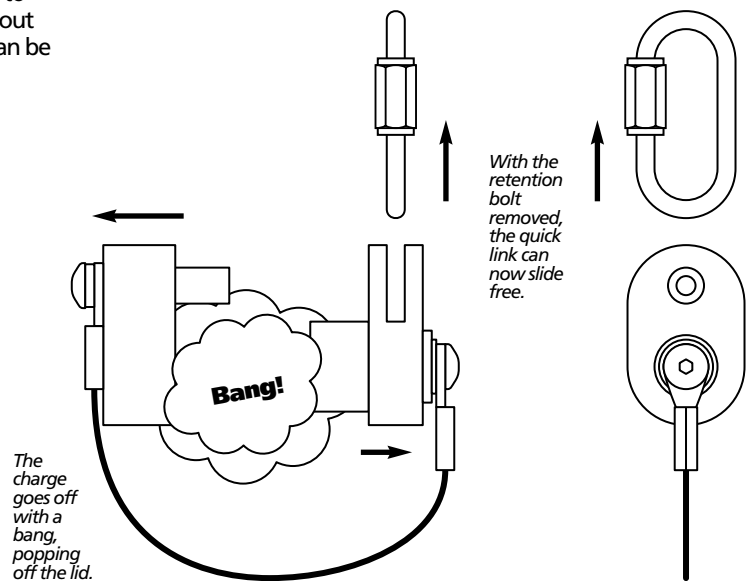

The charge goes off with a bang, popping off the lid.

With the retention bolt removed, the quick link can now slide free.

Configurations

The following shows a variety of ways tethering can be arranged to meet a particular need.

Behind the Mount

In this configuration, tethering is accomplished by attempting to pull the body of Tether through your rocket shock mount hardware, usually either an eye bolt or a U-bolt. Providing your hardware is the appropriate size to allow the retention tabs to pass through, but not large enough to allow the entire device to pass through, this is a quick and simple method to utilize Tether. The unit itself, being unable to pass through, will keep the retained item tethered until the charge is fired.

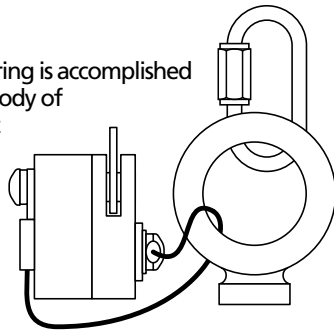

Passing the retention cable through the eye of the mount, twist-wiring or tie-wrapping the cable to the eye will serve to keep the fired device attached to your rocket.

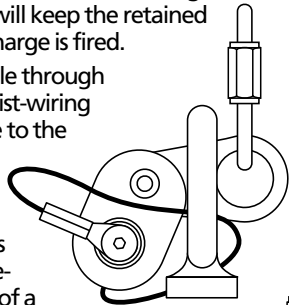

There are some variations to this method. Use a one-eighth quick link instead of a retention tab.

Or feed a line of kevlar, nylon or even steel cable through your shock mount and behind the retention bolt in tether.

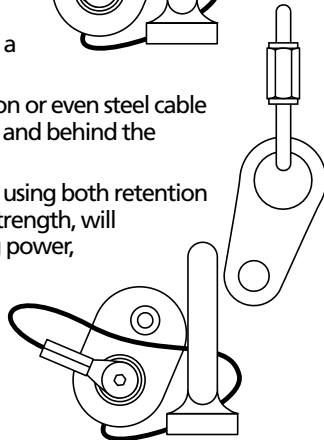

For high force applications, using both retention tabs side-by-side for extra strength, will provide extreme anchoring power, tethering and releasing loads up to 500 pounds.

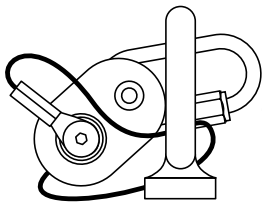
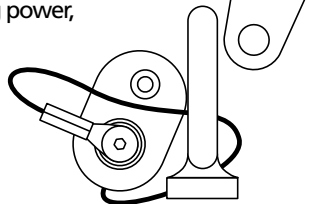

Quick Link

Kevlar, Nylon or Steel Cable

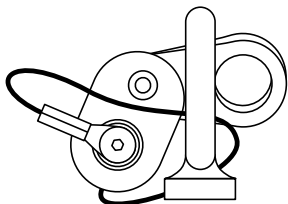
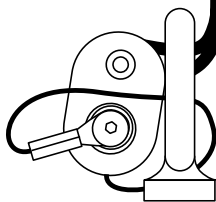

Retention Tabs (included with Tether)

Behind a Link

Similar to the behind-the-mount method, this uses a quick link attached to the anchor point, such as the shock mount. This alternative method would be used if the shock mount does not lend itself to the first method either due to position or size. Also, as in the first method, retention tabs may be used, or another quick link, or just a line.

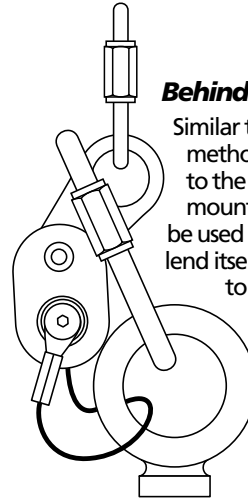

In-Line Method

Using both retention tabs, this time positioned opposing each other, will provide retention with little stress applied directly to the unit itself. Cleanest release is achieved with this method as well. A good application of this method is one where less pull from the tethered item may be expected, however arranging Tether this way can still support a great deal of force as well — up to 300 pounds.

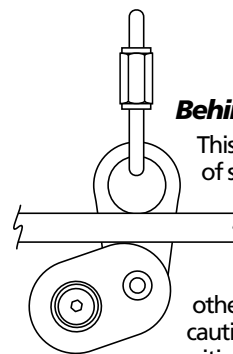
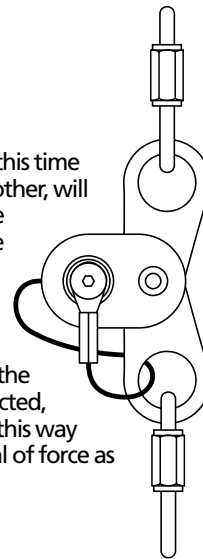

Behind a Bulkhead

This method requires a small amount of structural modification. Cut a slot about one inch long by one-eighth inch wide in a bulkhead where you have access to the other side. A word of caution: This method positions Tether inside your rocket during discharge. Take measures to insure that Tether does not damage your rocket's airframe or electronics. Read the warning in the following section, "Internal Triggering Concern."

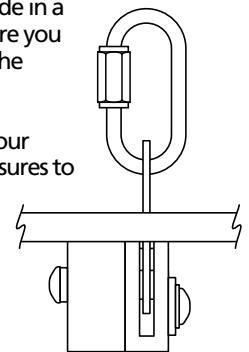

Alternate Attachment

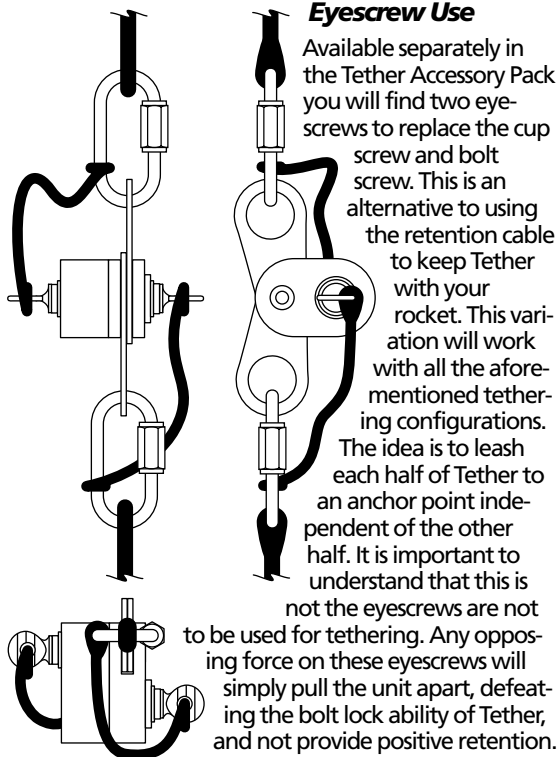

Multi-Point Release

This method is used when the need to release more than one item exists. Snaking the retention cable through the released items will allow several items to be released individually and simultaneously. It is easy to incorrectly utilize this method, and should *only* be used when there is little stress expected. Be certain to follow the diagram closely and practice this arrangement to become familiar with how tethering and release is accomplished. Visualize a bend in the cable going through the eye of the released item, then behind the retention bolt. When Tether is tripped and the bolt is gone, ask yourself: will this loop of cable pass through the released items? When using quick links, it is easy to accidentally position the quick link around the wrong part of the cable. Take care to avoid this. Additionally, the anchored point *must* be on the part of the cable between the cup screw and the items to be released. Anchoring on the lid side will allow the lid to be pulled off when tension is applied, defeating positive retention. Test this by pulling on the released items after hook-up.

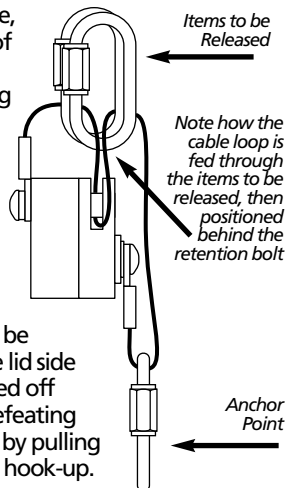

Mounted

You may choose to actually mount the Tether cup to a bulkhead or other structural part inside your rocket. This is accomplished by using the provided mounting screw, installed in the cup backwards to the original basic configuration. First pass cup mounting screw **L** through flat washer **K** and into hole in flanged side of ignitor seal **J** and thread until flange meets flat washer **K** and stop (*do not tighten*). Slide ignitor seal **J** into the charge cavity in Tether cup **H** until the flange on ignitor seal **J** meets bottom of cavity. Tightening will cause ignitor seal **J** to expand the end protruding out the back of Tether cup **H**. After loading a charge and tightening ignitor seal **J**, you will have a length of cup mounting screw **L** available as a threaded stud to mount Tether cup **H** with.

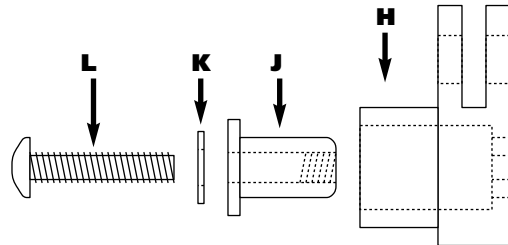

Pass this "stud" through a hole in a bulkhead and thread a #8/32 nut on from the other side of the bulkhead. Another variation is to install a #8/32 T-nut or blind nut on the bulkhead, and thread the cup mounting screw into before it before tightening and expanding the seal. As you expand the seal, you will also be drawing the cup down to the bulkhead. Or after tightening the screw and expanding the seal, rotate the entire Tether cup (space providing) to thread the stud into the T-nut, and snug the cup to the bulkhead. If mounting the unit to a bulkhead which will remain inside your rocket, take into consideration the position is critical to avoid Tether causing damage to your rocket upon discharge. Read the warning in the following section, "Internal Triggering Concern."

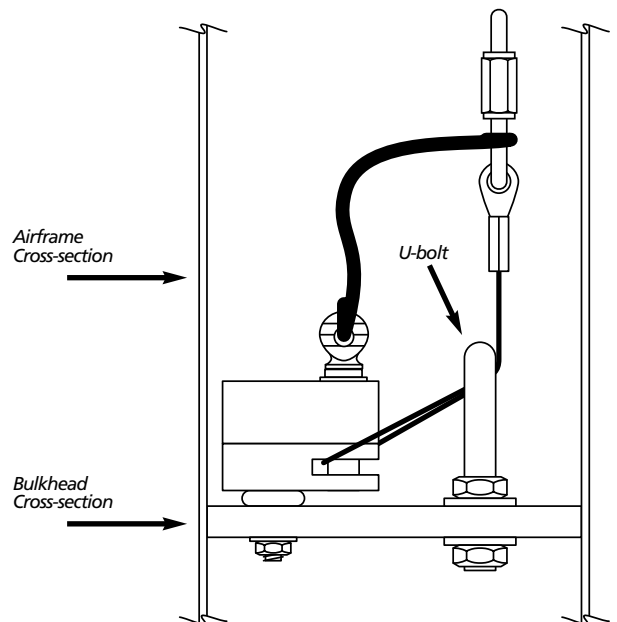

Recovery Arrangements

Reefed Main

This is the simplest arrangement because though a drogue chute could be used, it is not needed. This arrangement requires the electronics bay to be forward of the recovery bay. Run your apogee charge down to the bottom of your recovery bay and pack wadding on top of it, then pack the main on top of that. The main event charge is loaded in Tether.

The apogee event separates the rocket and deploys the main chute, reefed by Tether. The rocket falls at a controlled rate under small drag provided by the reefed main chute and aerodynamic instability of separation. When the main deployment altitude is reached, the charge is fired and Tether releases the reef, allowing the main to fill.

Minimum diameter enthusiasts and smaller rocket flyers will find this useful.

Configurations used in this recovery arrangement are *Behind the Mount*, *Behind a Link*, or *In-Line Methods*

How you reef the chute is open to many possibilities, but here is the most basic method. You may want to experiment and expand upon this method.

This is similar to the normal packing of a chute. Using a nomex chute protector, hold it open but slightly folded like a taco and Z-fold the chute, lines first, into the fold, back and forth until the entire chute is folded. Fold both side of the nomex over the chute.

Make a leash out of a short length of nylon or kevlar by tying a loop at each end and in the middle. Wrap the leash around the middle of the chute, bringing one end loop and the middle loop together. The Tether bolt will pass through these two loops, holding the bound chute. Pull the other end loop through a hole on the nomex and attach to some point on the recovery system to keep from losing your leash and nomex after main event.

When Tether is triggered, it will release the two loops, the leash will unbind the chute and the main will fall out of the nomex and fill.

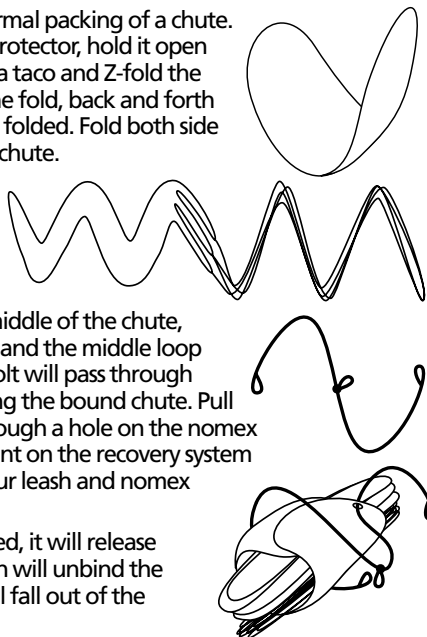
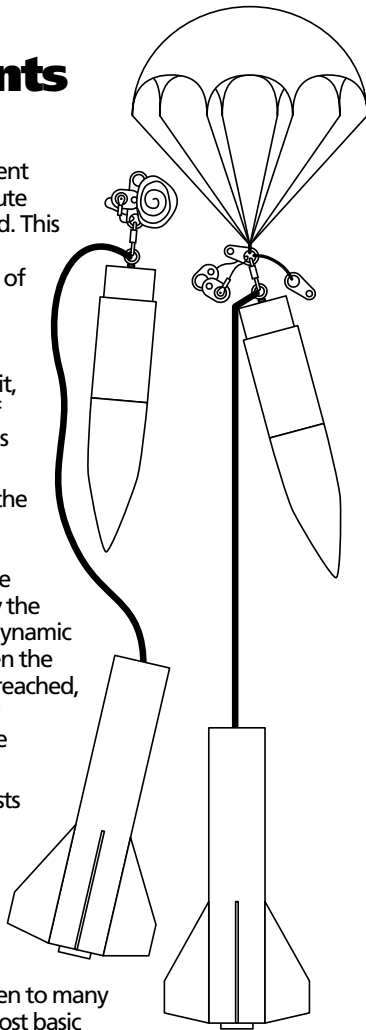

Tethered Drogue

Larger rockets may incorporate this somewhat more obvious arrangement. Using the *Behind a Bulkhead*, or *Mounted* configuration, this arrangement is for rockets with an electronics bay aft of the recovery compartment.

Attach a line from the crown of the main chute to a drogue chute, and tie in a loop or quick link a short ways up the line from the crown. Attach the loop to Tether and pack the main like normal on top, shock cord first, then shroud lines, then skirt and crown last.

Then pack a generous amount of wadding on top of the main, to protect it from the apogee event charge that will deploy the drogue. Place your apogee charge on top of the wadding and pack more wadding on top of it, then pack your drogue as you normally would.

At apogee, the charge inside the wadding will separate the rocket and deploy the drogue chute. The chute will open and pull against Tether. At main deployment altitude, the main event charge in Tether fires, releasing the loop in the line from the drogue to the main, thus allowing the drogue to pull the main out, and the main fills.

If you are concerned about the main sliding out early, fashion two loops in the drogue line and use the *Multi-Point Release* method to release both loops. Attaching two points on the drogue line will create a loop in the line that can be pulled over the bundled main for extra retention of the main chute. When Tether is triggered, both points are released, letting go of the loop over the main from both sides.

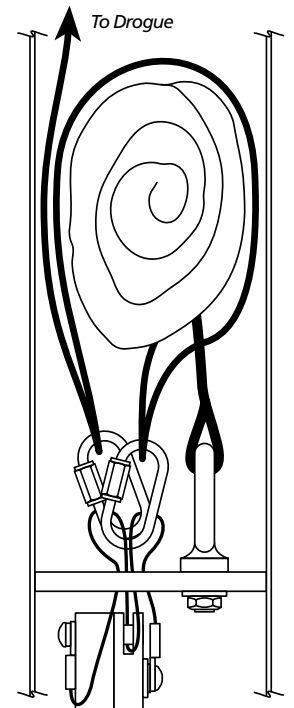
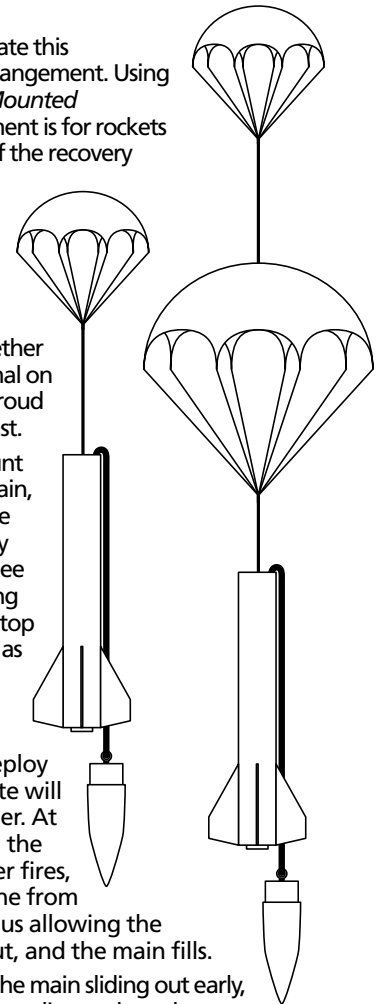

Deployment Bag

Similar to the *Reefed Main* arrangement, except this must use a drogue chute to deploy the main chute, and a deployment bag is used for the main instead of a leash to keep the main from opening.

Make a hole in the bottom of your deployment bag and feed the end of a small length of shock cord through. The cord should come out of the bag and the other end attach to the connection point of the main chute shrouds. Pack the shock cord in the bag first, followed by shroud lines, then the main chute skirt, and crown last. Attach a line as in the previous arrangement from the crown to the drogue.

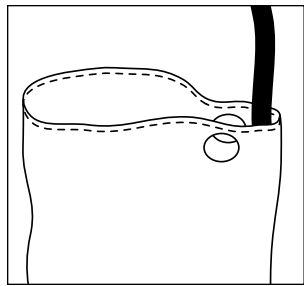
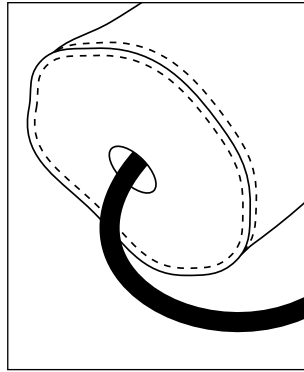

Make two small holes at the edge of the deployment bag, about one inch apart, then bring the drogue line to the edge of the bag, between the two holes, and fold the edge of the bag around the line, bringing the two holes together. Run Tether's retention cable through the holes, using the *Multi-Point Release* configuration.

As in the *Reefed Main* arrangement, electronics should be forward of the recovery. Run your apogee charge down to the bottom of your recovery bay and pack wadding on top of it, then pack the drogue chute, then the deployment bag with the main inside last. If there is room, you may want to position the drogue forward of the main deployment bag just in case of a worse case chance of the apogee charge not adequately deploying everything, the drogue will be the first thing out, which should pull everything else out.

Upon apogee event deploying the drogue, pulling on the main, but Tether is holding the mouth of the deployment bag shut until main event. Tether is triggered and the drogue can now pull the main out of the bag and fill.

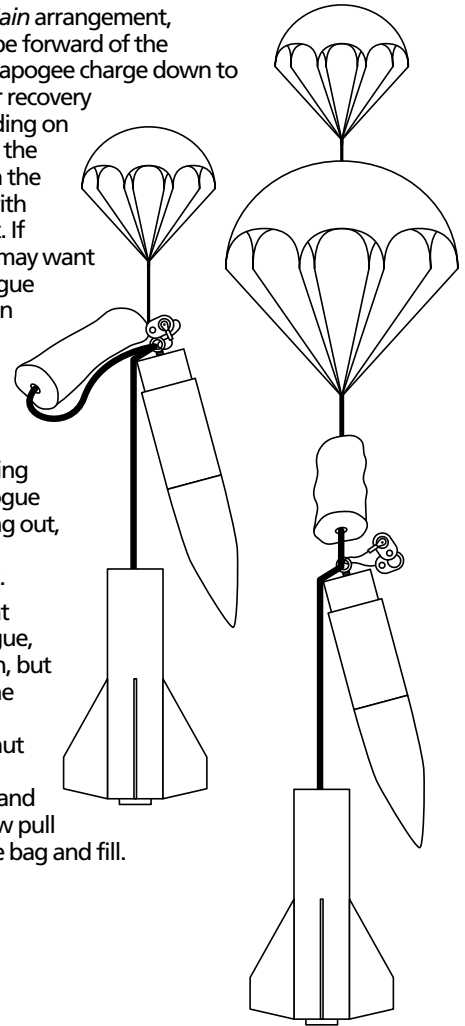

Internal Triggering Concern

When utilizing a tethering method that requires Tether to be inside your rocket airframe when triggered, be aware that Tether comes apart with great speed and force. Take extra measures to insure that damage to your rocket does not occur. Reinforce areas of impact with additional layers of airframe material so that these areas may withstand the force of discharge. Placing padding or packing these areas with wadding will help protect against impact. Orientation of the device itself may be all that is necessary. As in the previous diagram, Tether is shown mounted to a bulkhead at the bottom of a parachute bay. This arrangement points the Tether lid to tumble down the airframe toward the opening,

aiming the discharge force in a direction which is unlikely to cause damage. Ideally, Tether should be positioned somewhere outside the rocket when triggering is to occur, so that Tether may freely fly apart without worry. You may want to incorporate a shunt to the charge ignitor to guard against Tether being triggered if a situation arises where, for example, the apogee event fails, leaving the now undeployed Tether located in position that would cause damage to the airframe. Of course, you may have bigger problems than what comparatively little damage Tether could inflict if your apogee event fails, however you will need to analyze your own unique design and attempt to determine your level of risk, and how to better avoid undesirable flight profiles.

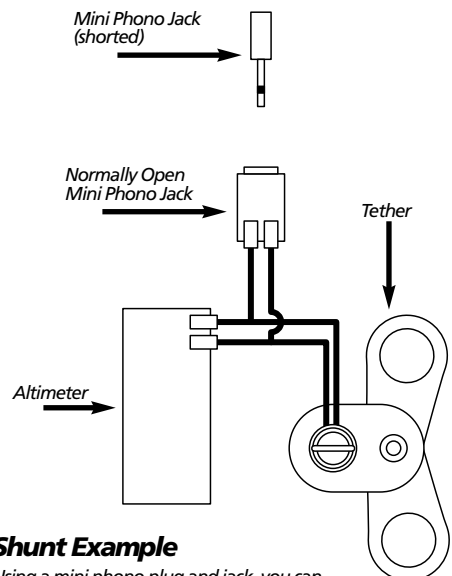
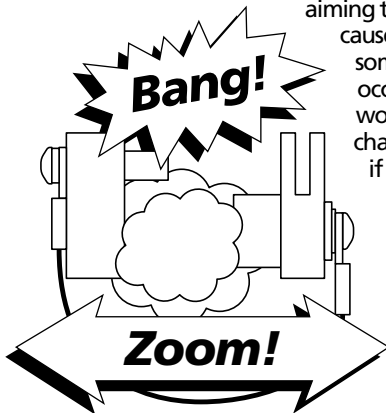

Shunt Example

Using a mini phono plug and jack, you can create a pull-pin shunt. When the plug is in the jack, the circuit is shorted, disabling Tether. By attaching the jack to the upper airframe, the apogee event will unshort the circuit.

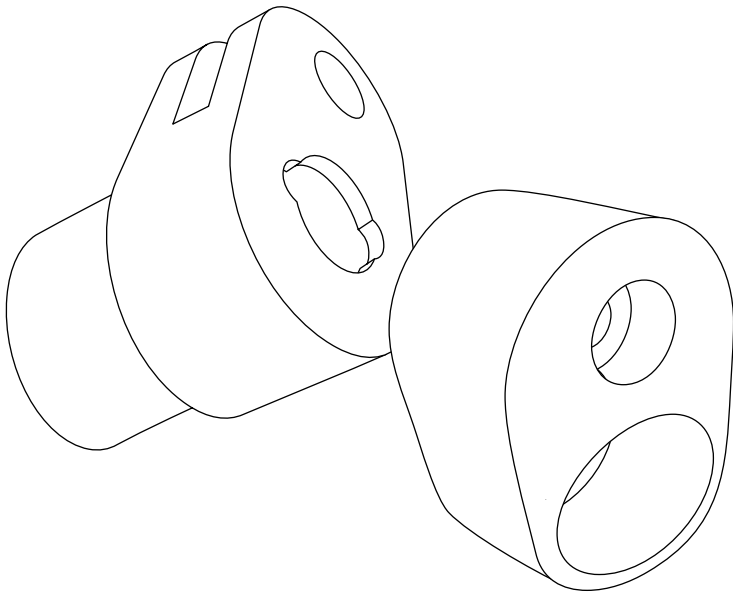

Defy Gravity

post office box 10357
glendale
california
91209
818 522 4924
tether@defyg.com
www.defyg.com